

MAIN FEATURES

- Freq. bands 2,4,5,6,10,11,14,18,23 GHz
- Payload capacity up to 210 Mb/s @ 40 MHz per unit, upgradable using XPIC onboard technology
- Modulation up to 1024QAM and virtually unlimited with the same modem
- Fully proprietary modem code, device independent (no dependency from single supplier)
- Straight ASI input
- Variable Payload Capacity and RF spectrum driven by TS bandwidth
- LIU plug-in board fully programmable to add any user interface (G.703 + WS, IP, etc.)
- MUX plug-in board which adds 8 programmable ASI I/O channels
- Ready for 1+1 configuration with modem and IF crossconnection with on-board Hot Standby and Hitless redundancy control
- SNMP embedded
- Local and remote upgrade (via TCP/IP) of Software and Firmware, with redundant flash memory for quick operations
- WEB browser interface for management & control
- Future encoder/decoder plug-in board

NEW RADIO LINK

is the new family of IRTE digital microwave link. Designed for Video application has been integrated with all the state of the art features needed by Broadcaster.

It features native ASI interface, with spectrum efficiency modulation based on proprietary modem firmware.

8 ch. Input/Output interfaces with embedded MUX One-way, 2-ways or "3-ways" terminal configuration for single-direction, bi-directional or independent frequency transceiver sites.

Scalable architecture for cost-effective network deployment.

High power transmitter for long back-hauls or difficult hops connection.

Fully programmable interface board for any customer connection (IP, G.703, etc.)

Very wide frequency band: from 2 up to 23 GHz.

Fully XCross-connected 1+1 configuration for Hot-Standby and Hitless applications



- 3 Unit rack all-indoor configuration with RF filter.
- Bi-directional configuration in the same 3RU mechanics
- Transceiver configuration in same 3RU mechanics with inbound and outbound fully independent (i.e. RX @ 7 GHz, TX @ 10 GHz)
- IDU+ODU configuration with 3 RU IDU and ODU RF Unit compatible with IRTE standard
- 2 Unit rack High Power Transmitter up to +37 dBm, fully controlled by the Radio Link

- 210 Mb/s
- Native ASI input
- Proprietary Modem firmware
- MUX 8Ch. ASI, G.703, IP

- Remotely upgradable
- LIU for fully programmable interfaces
- Web Browser and SNMP management

INDOOR version

HPA
High Power Transmitter:
Up to +37 dBm
2 unit rack



DIGITAL RADIO LINK
3 unit rack

OUTDOOR version



BLOCK DIAGRAMS

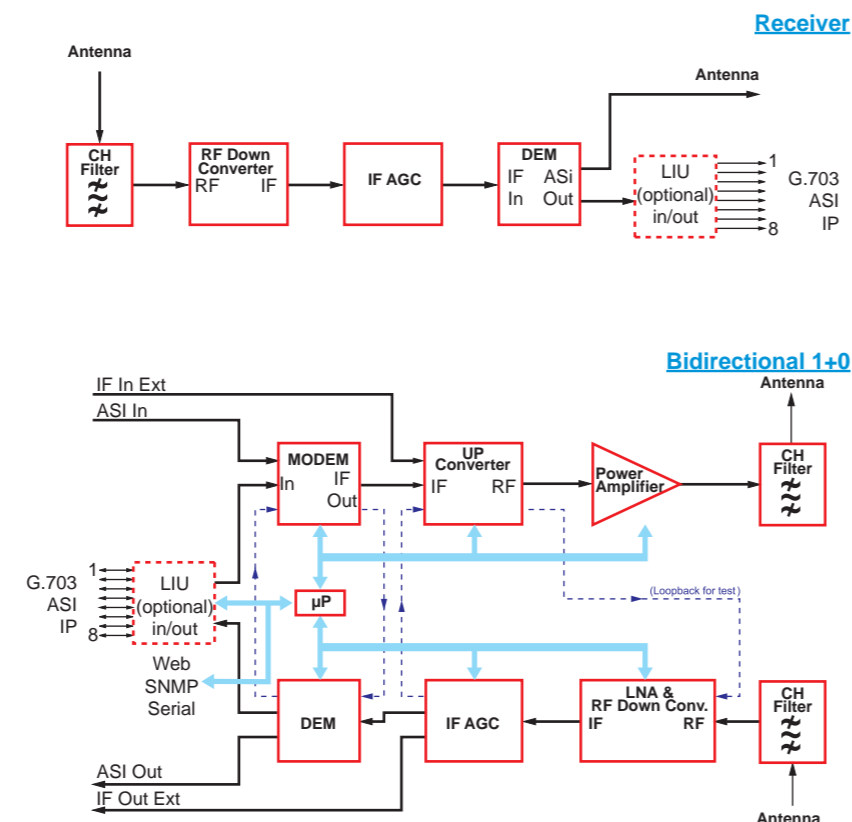
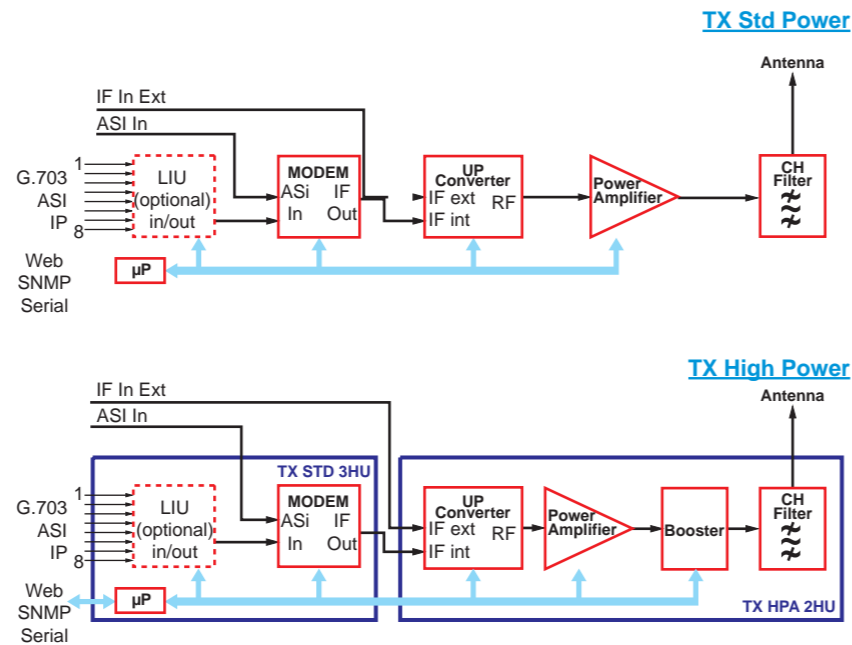

RECEIVER SPECIFICATION

Threshold at 10^{-6} BER

Modul. Capacity	Channel Spacing	2 GHz	4 GHz	6L GHz	6U GHz	10 GHz	11 GHz	14 GHz	18 GHz	23 GHz
		28 MHz	28 MHz	28 MHz	40 MHz	28 MHz	40 MHz	28 MHz	28 MHz	28 MHz
34Mb/s	4QAM	-84 dBm	-84 dBm	-84 dBm	-84 dBm	-83 dBm	-84 dBm	-82 dBm	-81 dBm	-79 dBm
34Mb/s	16QAM	-79 dBm	-79 dBm	-79 dBm	-79 dBm	-78 dBm	-79 dBm	-77 dBm	-76 dBm	-74 dBm
45Mb/s	16QAM	-79 dBm	-79 dBm	-79 dBm	-79 dBm	-78 dBm	-79 dBm	-77 dBm	-76 dBm	-74 dBm
45Mb/s	64QAM	-76 dBm	-76 dBm	-76 dBm	-76 dBm	-75 dBm	-76 dBm	-74 dBm	-73 dBm	-71 dBm
51Mb/s	16QAM	-79 dBm	-79 dBm	-79 dBm	-79 dBm	-78 dBm	-79 dBm	-77 dBm	-76 dBm	-74 dBm
51Mb/s	64QAM	-76 dBm	-76 dBm	-76 dBm	-76 dBm	-75 dBm	-76 dBm	-74 dBm	-73 dBm	-71 dBm
155Mb/s	64QAM	-73 dBm	-73 dBm	-73 dBm	-73 dBm	-72 dBm	-72 dBm	-71 dBm	-70 dBm	-68 dBm
155Mb/s	128QAM	-71 dBm	-71 dBm	-71 dBm	-71 dBm	-70 dBm	-70 dBm	-69 dBm	-68 dBm	-66 dBm

TRANSMITTER SPECIFICATION:

Power Output (Standard Unit)*

Modulation	2 GHz	4 GHz	6L GHz	6U GHz	10 GHz	11 GHz	14 GHz	18 GHz	23 GHz
FM	30 dBm	30 dBm	30 dBm	30 dBm	30 dBm	30 dBm	30 dBm	27 dBm	24 dBm
4QAM	29 dBm	27 dBm	28 dBm	28 dBm	27 dBm	27 dBm	27 dBm	25 dBm	22 dBm
16QAM	26 dBm	24 dBm	25 dBm	25 dBm	24 dBm	24 dBm	24 dBm	22 dBm	19 dBm
32QAM	26 dBm	24 dBm	25 dBm	25 dBm	24 dBm	24 dBm	24 dBm	22 dBm	19 dBm
64QAM	24 dBm	23 dBm	24 dBm	24 dBm	23 dBm	23 dBm	22 dBm	20 dBm	17 dBm
128QAM	23 dBm	22 dBm	23 dBm	23 dBm	22 dBm	22 dBm	21 dBm	19 dBm	16 dBm

Power Output (with High Power Amplifier-Optional)*

Modulation	2 GHz	4 GHz	6L GHz	6U GHz	10 GHz	11 GHz	14 GHz	18 GHz	23 GHz
4QAM	39 dBm	37 dBm	37 dBm	37 dBm	36 dBm	36 dBm	36 dBm	N.A.	N.A.
16QAM	36 dBm	34 dBm	34 dBm	34 dBm	33 dBm	33 dBm	33 dBm	N.A.	N.A.
32QAM	36 dBm	34 dBm	34 dBm	34 dBm	33 dBm	33 dBm	33 dBm	N.A.	N.A.
64QAM	34 dBm	33 dBm	33 dBm	33 dBm	32 dBm	32 dBm	31 dBm	N.A.	N.A.
128QAM	33 dBm	32 dBm	32 dBm	32 dBm	31 dBm	31 dBm	30 dBm	N.A.	N.A.

* After the Channel Filter, over entire band, inside temperature range

ENVIRONMENT

	Full indoor / IDU	ODU
Reference Standards	ETSI EN 300 019-1-3 class 3.2	ETSI EN 300 019-1-4 class 4.1
Storage	ETSI EN 300 019-1-1 class 1.2	ETSI EN 300 019-1-1 class 1.2
Transport	ETSI EN 300 019-1-2 class 2.3	ETSI EN 300 019-1-2 class 2.3
Temperature: Operation	-10°C ÷ +45° C	-33°C ÷ +45° C
Storage	-40°C ÷ +80° C	-40°C ÷ +80° C
Humidity	95% (non condensing) @ 45° C	100%
Max Altitude	4500 m a.s.l.	4500 m a.s.l.