

CHARACTERISTICS

Parte RF	
Frequency Range	470 – 862 MHz (Optional: B III - BL)
Output Power (DVB)	50W DVB-T @ -36 dB Shoulder (typ.) uncorrected
Output Power(compression @ 1 dB)	200 W typ. CW mode
Gain	47 dB nominal
Gain UNFLATNESS	± 1.5 dB
Operating Temperature	0 to +45 °C
Humidity	fino a 90% (not condensing)
Current Consumption	1.3 A max @ 230 V DIGITAL -approx-
Current Consumption	1.3 A max @ 230 V ANALOG -approx-
R.O.S. -INPUT-	Min. -16 dB (Typ. -20dB)
R.O.S. -OUTPUT-	Min. -18 dB (Typ. -20dB)
Remote Controls	
Enable	RF Enable ON / Stand By
Gain (optional)	Gain setting
Remote PC or Control Unit (RS232/RS485) Display	
Status / alarms	Note
Enable	ON/STAND BY
RF Faults (ref. to nominal values)	ACTIVE if Gain < 6dB or 3dB (SW selected)
°C max	ACTIVE when RF Thermal Protection is ON
Pin max	ACTIVE when RF Overdrive Protection is ON
VSWR max	ACTIVE if VSWR max Protection is ON
I max	ACTIVE when Current is too High
Measurements	
RF in	Input Power in uW (RMS for DVB-T/ for analog)
RF out	Output Power in W (RMS for DVB-T/ p.s. for analog)
RF REF	Reflected Power in W (RMS for DVB-T/ p.s. for analog)
RF Heatsink Temperature	Temperature in °C
IDC RF Section	Value in A
VDC	PS Output Voltage
Self Protections	
RF Thermal Protection	
Overdrive (1)	
Max SWR (2)	
Trip Lock Out	
(1) maximum P and (2) MAX threshold of VSWR must be set on the operating channel, with the appropriate signal type.	
Mechanical data and Interfaces	
Dimensions	19" Standard, 2 HU, depth. 500 mm
Mass	15 Kg approx
RF in	Connectors SMA, Rear panel (Gap Filler version only)
RF out	Connectors N, Rear panel
RF monitor	Connectors SMA, Rear panel (Front Panel on TU50M only)
RS485	D 9 pin Rear panel
PA Control	D 9 pin Rear panel
Parallel I/O	D 15 pin Rear panel
Ethernet Management	RJ45 Rear panel
ASI 1 IN HP, ASI 2 IN HP, ASI 1 IN LP, ASI 2 IN LP (TU50)	4 x SMA, Front panel(75 Ohm)
ASI over IP IN (TU50M only)	RJ45, Front panel
RF IN (TU50M only)	SMA, Front panel (50 Ohm)
GPS Antenna	SMA, Front panel(50 Ohm)
10MHz In	SMA, Front panel(50 Ohm)
10MHz Out	SMA, Front panel(50 Ohm)
1pps In/Out	SMA, Front panel(50 Ohm)
Exciter Monitor	SMA, Rear panel

Above are subject to change without notice

TU50 & TU50M

50 Wrms DVB-T/DVB-H Transmitter / Exciter / Gap Filler / Repeater

TU50 is a complete equipment which includes the Modulation and Amplification sections. The Unit, designed for DVB-T and DVB-H applications in UHF Band, is realized using the most advanced technologies to reach the highest levels of reliability and performance. Conceptually is an equipment for immediate fast installation. The TU50 system allows a flexible configuration and can be used also as Driver and Control Logic for transmitters of higher power up to 20 KW, or also in Dual Drive configuration with automatic switch over.



- High performance COFDM modulator
- Full LD-MOS Power Amplifier
- 50 Wrms output DVB-T/DVB-H
- Agile broadband (470-862 MHz)
- Internal GPS receiver
- Internal DVB-S/S2 SAT receiver (Optional)

- Easy maintenance without special tools
- Control software included
- Automatic precorrection (Optional)
- Extremely strong mechanical structure
- VHF band (TV50) available on request
- RS232-RS485-SNMP-WEB management

- ASI over input (TU50M only)
- RF input repeater no-echo (UHF) (TU50M only)

Data are subject to change without notice

HW STRUCTURE:

HW STRUCTURE:

The HW structure is composed of the following 4 sections:

- DVB-T or HTeamCast Modulator MAX2012 (TU50) or MAXI2012 (TU50M)
- RF section
- CPU Board
- AC-DC Power Supply

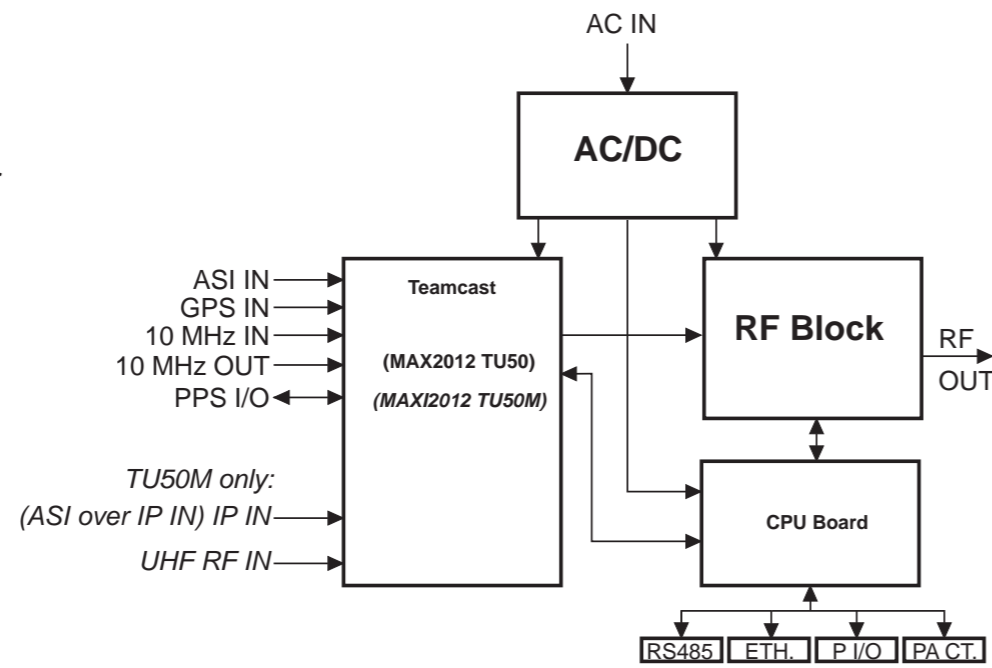

The CPU Board is the interface linking all the sections.

RF Line Up (RF Block)

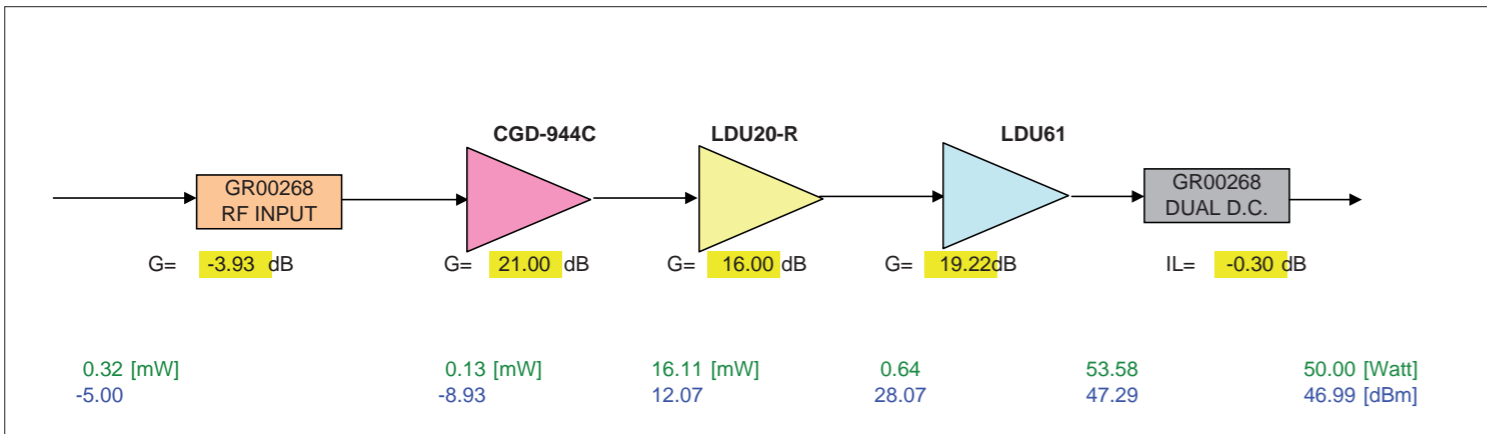

AVAILABLE OPTIONS:

The TU-50 take advantage of the full range of TeamCast product line, and changing the Modulator type it is possible to have the following applications:

- Gap-Filler without Echo Cancellation (TU50M only);
- DVB-T or H in L Band (with Pallet and different HW);
- Dual Cast Modulator (External Analog to SDI converter);
- DAB-T-DMT Modulator.

Note: The GPS is normally integrated inside the TeamCast Modulator. If the actual specifications of standard GPS do not satisfy the desired SFN Network or it is preferred to use a version without the GPS, this one must be placed in a separate sub-rack.

Control System specifications:

The Control Processor Unit (CPU) is the intermediate device among the TeamCast Modulator, the RF part and the User who can get the equipment parameters in four modes:

- TCP-IP SNMP (ETHERNET CONNECTOR)
- TELNET (RS232)
- RES1 PROTOCOL (RS485)
- WEB INTERFACE

An additional Port called as "Control PA" is available on the rear panel of the equipment.

The mode using RS485 FULL DUPLEX 56688 8, n, 1 could be specialized as HALF DUPLEX, in such a way to use the ALGORAB protocol.

The presence of a I-O in paralell allows to use of the Dual Drive option, or the remote telecontrol.

FRONT PANEL

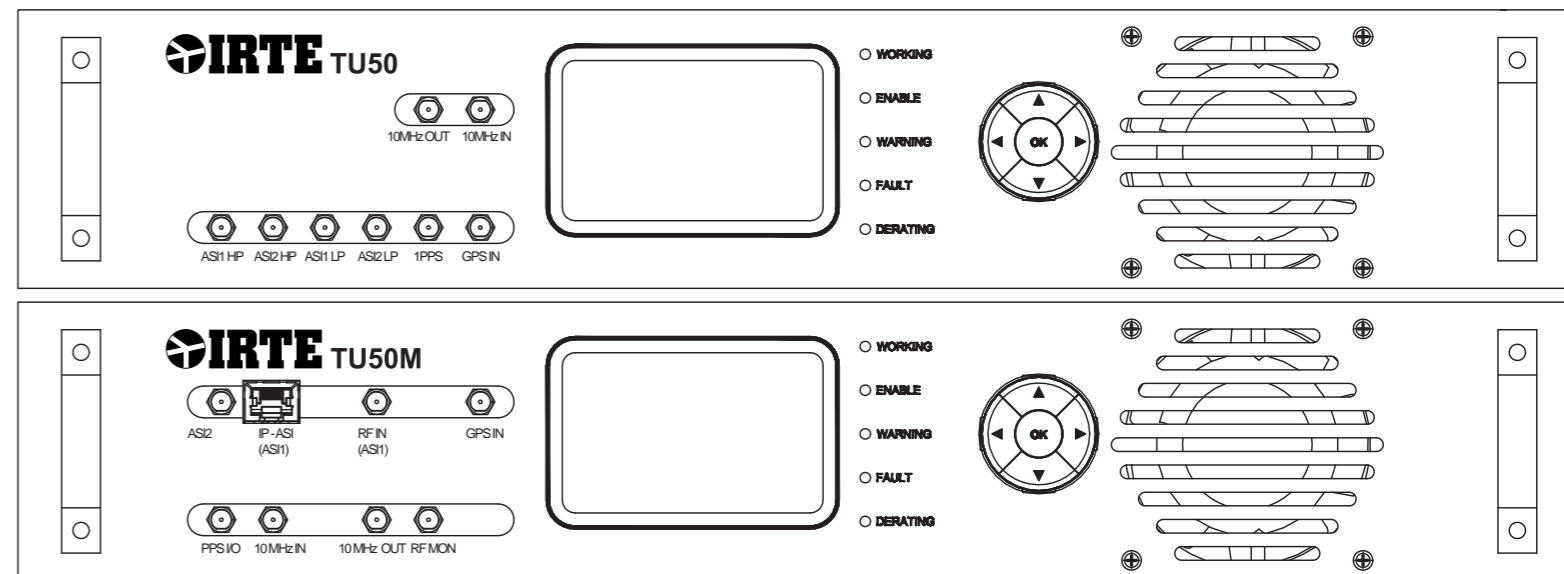

REAR PANEL

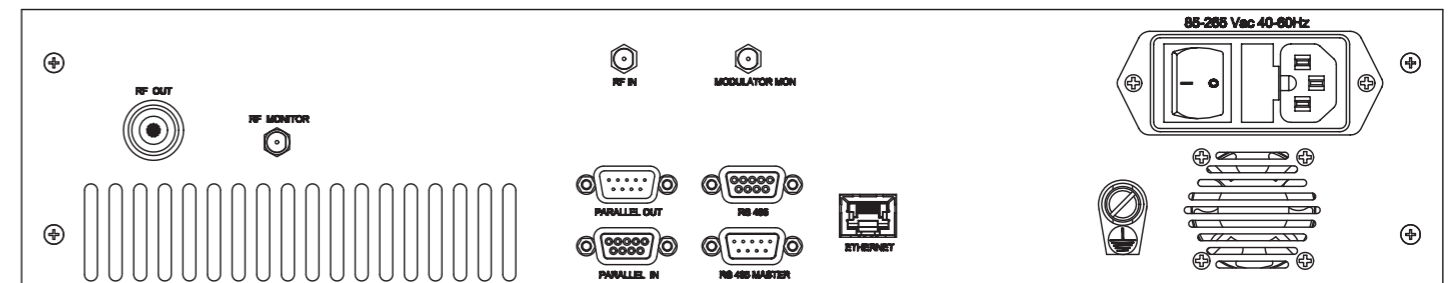

TU50 & TU50M

50 Wrms DVB-T/DVB-H Transmitter / Exciter / Gap Filler / Repeater