



IRTE

RRD

RETI
RADIOTELEVISIVE
DIGITALI

MOBILE TELEVISION DVB-H GAP-FILLER

All-in-one Transmitter for Full Network Coverage



- UHF AGILITY
- ON BOARD PROFESSIONAL SAT RECEIVER
- ON BOARD DVB-T COMPLIANT GPS RECEIVER
- 50 W or 100 W r.m.s. OUTPUT POWER
- 20 dB OUTPUT POWER DYNAMIC RANGE
- MER: 36 dB IN THE FULL POWER AND FREQUENCY RANGE
- DIGITAL PRECORRECTION

OUTPUT POWER REMOTE MANAGEMENT (VIA MIP OR SNMP)



MOBILE TELEVISION

INTRODUCTION

The equipment described here below is a TRANSMITTER that allows to receive a signal coming from satellite, to demodulate it to have the ASI format, to present it into DVB-H standard by a DVB-H modulator and to convert this IF frequency into the final UHF frequency with the associated output power. It is well designed for working also as a GAP-FILLER.

The equipment also accept two external ASI signals (MAIN if in non-hierarchical mode or HP + LP if in hierarchical mode) in standard electrical format or an MPEG-over-IP Transport Stream input using IP-GBE interface.

It is also equipped with a GPS RECEIVER to generate the required high stability reference.

The equipment has also the capability to be managed via GBE (Giga Bit Ethernet)

The main features of such equipment are:

- DVB-H COMPLIANT
- UHF AGILITY
- INTEGRATED PROFESSIONAL SAT RECEIVER
- 50 W or 100 W r.m.s. OUTPUT POWER
- HIGH OUTPUT POWER DYNAMIC RANGE (20 dB) SELECTABLE BY SOFTWARE OR REMOTE
- MER: 36 dB MIN VALUE AT ANY OUTPUT POWER AND FREQUENCY
- RF SOFT START
- DIGITAL PRECORRECTION
- MANAGEMENT OF THE OUTPUT POWER BY MIP OR SNMP
- ON BOARD DVB-T COMPLIANT GPS RECEIVER
- ALARM LOG
- 19” RACK STANDARD

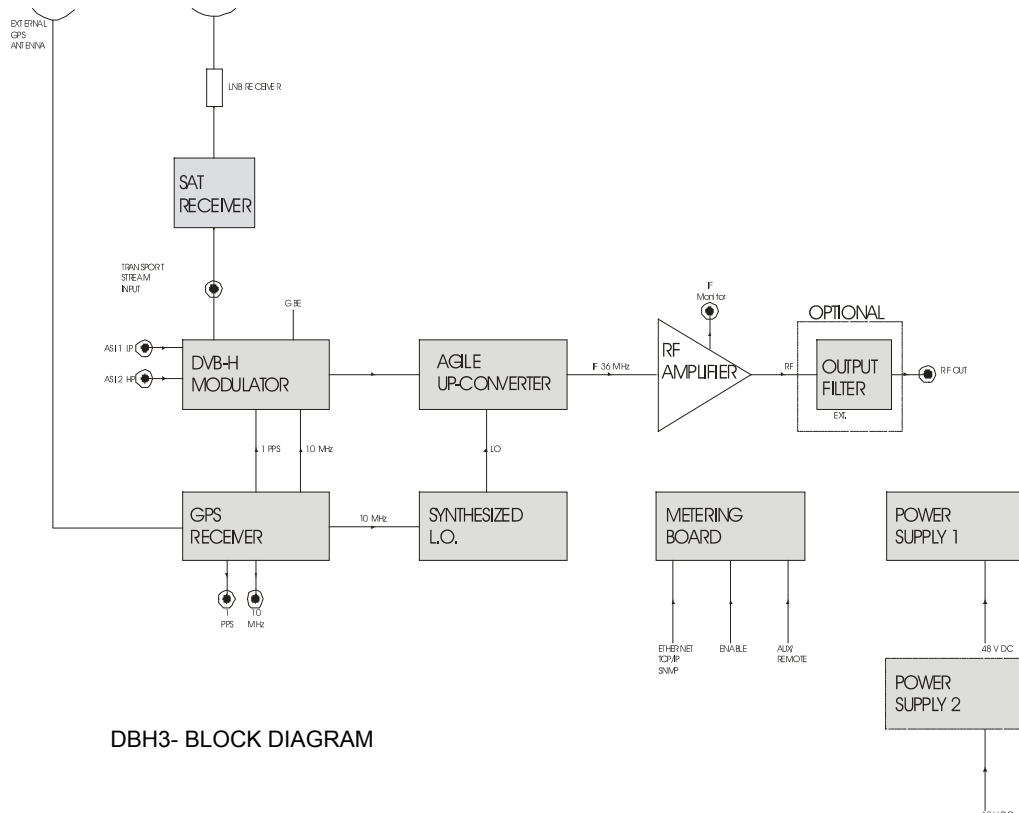

DBH3- BLOCK DIAGRAM

All specifications, characteristics and circuit descriptions set forth in this manual are subject to change without notice.

TECHNICAL SPECIFICATIONS	
GENERAL	
Available standards	DVB-T, DVB-H
Operating frequency range	470 - 770 MHz (470 – 860 MHz optional)
Cooling	Forced Air
Main supply	48 V DC with polarized connector
Power consumption	500 VA (50 W Version) 1000 VA (100 W Version)
MECHANICAL AND ENVIRONMENTAL	
Dimensions	483 mm (W) x 470 mm (D) x 135 mm (H)
Weight	18 kg approx.
Operating temperature	From -10°C to +45°C
Storage temperature	From -30°C to +80°C
Maximum relative humidity	99%, non condensing
INPUT PARAMETERS	
ASI INPUT PARAMETERS	
Input Signal	MPEG-2 Transport Stream, ASI format
Input Level	800 mV (±10%)
Data rate	270 MB/s
Data rate error	±3ppm
Input connector	BNC
Input impedance	75 Ω
LAN PARAMETERS	
Full control and management via browser or via SNMP using TCP/IP port	
GBE PARAMETERS	
MPEG over IP Transport Stream input using GBE port	
Full control and management via SNMP protocol using GBE port	
SATELLITE	
Input Signal	IF (950 – 2150 MHz) from LNB sat receiver
Input connector	F female
Input impedance	75 Ω
LNB power supply	from transmitter
GPS	
Input connector	TNC female
Antenna power supply	from transmitter, 5V DC
MODULATION	
IFFT	2k, 4K and 8k
Guard Interval	1/4, 1/8, 1/16, 1/32
Code Rates	1/2, 2/3, 3/4, 5/6, 7/8
Modulation	OFDM
OFDM Carrier Modulation	QPSK, 16QAM, 64QAM
Precision Offset	Integrated (exact 1Hz step at all BW)
SFN Function	Integrated
Network Delay Compensation	Automatic
Bandwidth	5MHz, 6MHz, 7MHz, 8MHz
BER	0 over a 5 hours period, measured
before RS decoding, typical	
MER	> 36 dB any output power
Eye aperture on vector constellation without IF filter	> 32dB
Virtual elastic store function to prevent data overflow	Integrated
Hierarchical mode	All DVB-T/H modes supported
Spectrum Inversion	Supported
OUTPUT PARAMETERS	
Connector	N Female (50 W Version) 7/16" Female (100 W Version)
Impedance	50 Ω
Load mismatch	2:1 Max. (with output isolator)
RF monitor connector	SMA
Nominal output power	50W / 100 W RMS
In-Band Flatness	± 0.5dB
Shoulders at F0 ± 4.3 MHz	≤ -36 dB (digital pre-correction inserted)

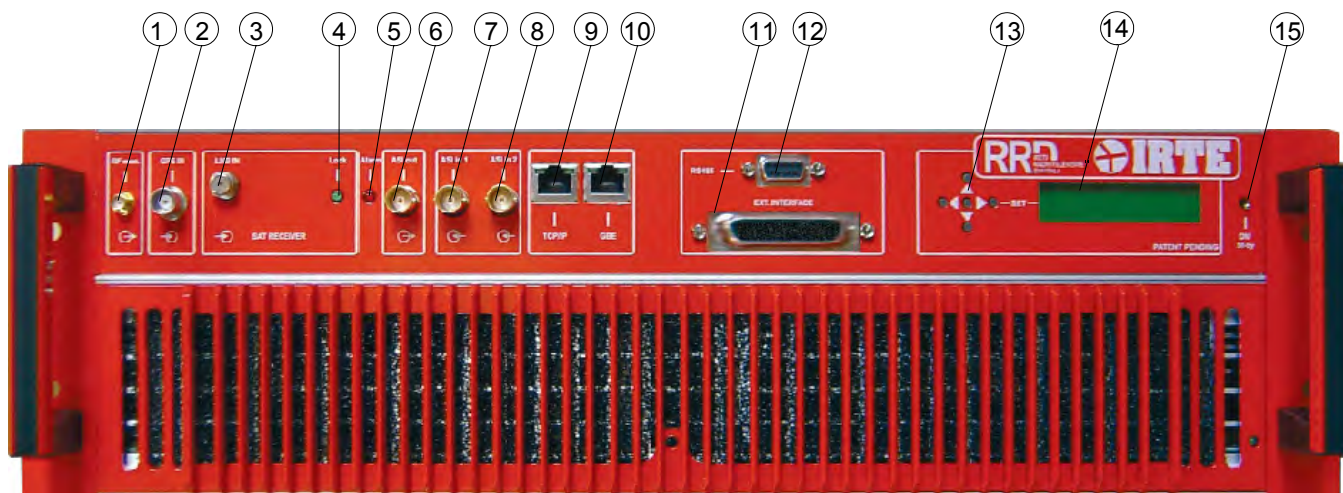

Front panel

n.	Label	Description
1	RF monitor	RF output monitor, BNC female connector.
2	GPS in	Input signal from GPS Antenna. TNC female connector.
3	RX SAT in	Sat IF input signal from LNB. F-type female connector.
4	SAT Lock	LED indicating RX SAT is OK.
5	Alarm	LED indicating general alarm occurring.
6	ASI out	ASI output. BNC female connector.
7	ASI in 1	ASI input MAIN, HP, LP software selectable. BNC female connector.
8	ASI in 2	ASI input MAIN, HP, LP software selectable. BNC female connector.
9	TCP/IP	TCP/IP device control connector.
10	GBE	Gigabit-Ethernet connector (MPEGoIP input and SNMP management).
11	TC/TS	DB50 Tele-Control and Tele-Signal connector.
12	RS485	RS485 Connector.
13	Push panel buttons	5 navigation push buttons.
14	LCD Display	Alarms and password monitoring display 2 x 20.
15	ON / St-by	LED indicating equipment power status

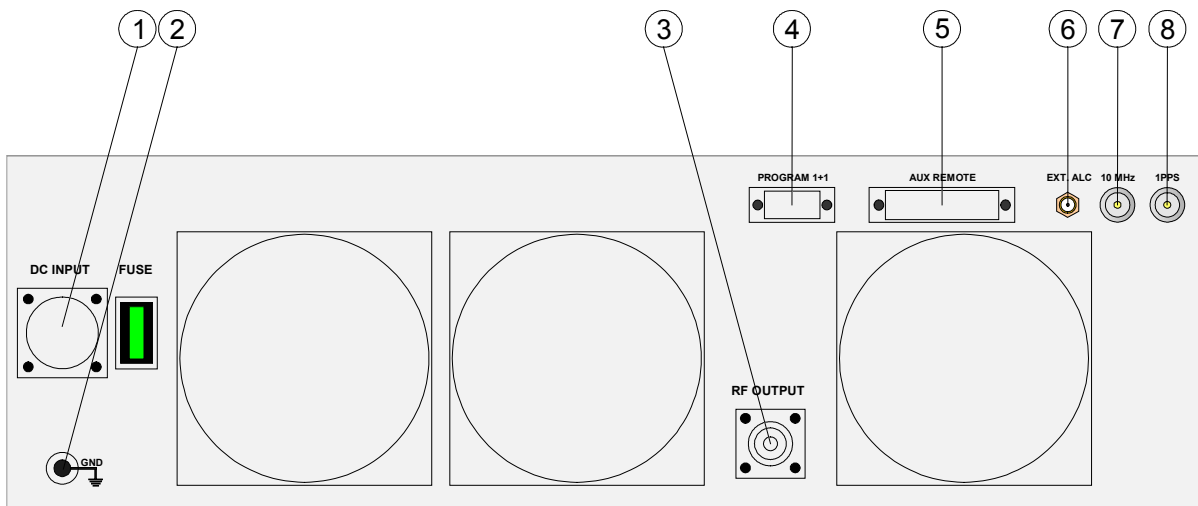

Rear panel

n.	Label	Description
1	DC IN	48 V input.
2	GND	Ground connector
3	RF OUTPUT	Type N (50W) or 7/16" (100 W) female connector, 50 Ω
4	PROGRAM 1+1	Sub-D 25 pin female connector for 1+1 option.
5	AUX REMOTE	Serial Link connector. It controls the external booster amplifier.
6	EXT ALC	External Automatic level control adjustment
7	10 MHz	10 MHz reference from external GPS
8	1PPS	1PPS reference from external GPS

1+1 and HIGH OUTPUT POWER CONFIGURATION (DBH-3 160 W rms)

